



INDUCTIVE AND CAPACITIVE SENSORS OVERVIEW



Capacitive sensors cylindrical and rectangular



Series:

... 12GM, ... 18GM, ... 30GM

Mounting:

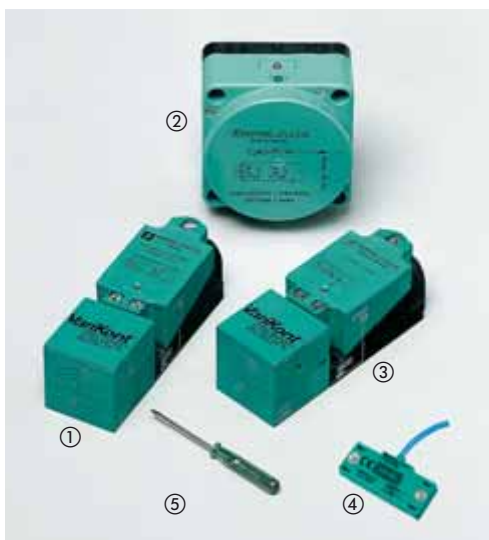

... F46, ... FP, VariKont

Electrical version

DC 3-Wire

E2 = pnp Normally Open

10 V DC ... 60 V DC
CJ ...

10 V DC ... 30 V DC
CB ... and CC ...

Sensing range	Part reference	Figure	Footnote
4	CJ4-12GM-E2	1	1) 2)
4	CJ4-12GM-E2-V1	10	1) 2)
8	CJ8-18GM-E2	2	1) 2)
8	CJ8-18GM-E2-V1	9	1) 2)
10	CJ10-30GM-E2	3	1) 3)
10	CJ10-30GM-E2-V1	4	1) 3)

Sensing range	Part reference	Figure	Footnote
2	CBN2-F46-E2	4	
2	CCN2-F46A-E2	5	
5	CBN5-F46-E2	4	
5	CCN5-F46A-E2	5	
10	CBN10-F46-E2	4	

DC 4-Wire

A2 = pnp, antivalent
Normally Open and
Normally Closed

10 V DC ... 60 V DC

10	CJ10-30GM-A2	3	1) 3)
10	CJ10-30GM-A2-V1	4	1) 3)

15	CJ15+U1+A2	3	1) 2)
40	CJ40-FP-A2-P1	2	

AC 2-/3-Wire

WS = Normally Open (2-Wire)
WÖ = Normally closed (2-Wire)

10	CJ10-30GM-WS	6	1) 3)
10	CJ10-30GM-WÖ	5	1) 3)

15	CJ15+U1+W	1	1)
40	CJ40-FP-W-P1	2	1)

NAMUR/EN 60947-5-6 nominal voltage 8 V DC

1	CJ1-12GK-N	7	
2	CJ2-18GK-N	8	
4	CJ4-12GK-N	7	
6	CJ6-18GK-N	8	

2	CBN2-F46-N1	4	
5	CBN5-F46-N1	4	
5	CCN5-F46A-N1	5	
10	CBN10-F46-N1	4	
10	CCN10-F46A-N1	5	

Footnotes: 1) Adjustable with potentiometer 2) Voltage range 10 V DC ... 30 V DC 3) Solid plastic housing on demand

Other electrical versions on demand

INDUCTIVE SENSORS CYLINDRICAL

Inductive sensors cylindrical

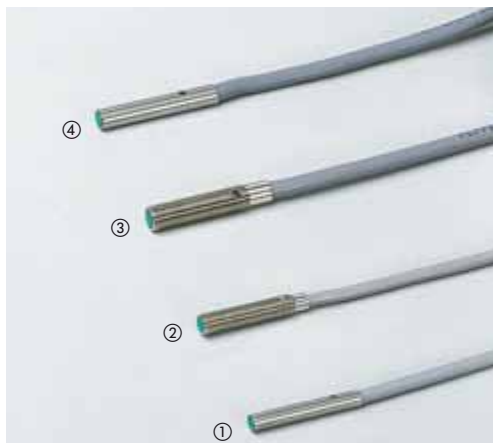

Series:

... 3, ... 4GM, ... 5GM

... 6.5, ... 8GM

Mounting:

embeddable

embeddable

Electrical version

DC 2-Draht

Z0 = Normally Open
Z1 = Normally Closed
Z4 = Normally Open
10 V DC ... 30 V DC

Sensing range	Part reference	Figure	Footnote
---------------	----------------	--------	----------

Sensing range	Part reference	Figure	Footnote
---------------	----------------	--------	----------

DC 3-Wire

E2 = pnp Normally Open

10 V DC ... 60 V DC
NJ ...

10 V DC ... 30 V DC
NBB .../NBN ...

10 V DC ... 30 V DC
NEB

increased sensing range

0.6	NBB0,6-3M22-E2	1	1)
0.6	NBB0,6-4GM22-E2	2	1)
1	NBB1-3M22-E2	1	1)
1	NBB1-4GM22-E2	2	1)
0.8	NBB0,8-4M25-E2	4	1)
0.8	NBB0,8-5GM25-E2	3	1)
0.8	NBB0,8-5GM25-E2-V3	-	1)
1.5	NBB1,5-5GM25-E2-V3	-	1)

1.5	NBB1,5-8GM40-Z1	7	
1.5	NBB1,5-8GM50-Z1-V3	9	
1.5	NCB1,5-8GM40-Z1	-	
1.5	NCB1,5-8GM50-Z1-V3	18	
1.5	NJ1,5-6,5-40-E2	8	
1.5	NJ1,5-8GM40-E2	7	
1.5	NJ1,5-8GM40-E2-V1	13	
1.5	NBB1,5-8GM25-E2	-	
1.5	NBB1,5-8GM20-E2-V3	1	
1.5	NBB1,5-8GM50-E2	11	
1.5	NBB1,5-8GM50-E2-V3	15	
2	NBB2-6,5M30-E2	12	
2	NBB2-6,5M25-E2-V3	16	
2	NBB2-8GM30-E2	-	
2	NBB2-8GM25-E2-V3	1	
2	NBB2-8GM30-E2-V1	17	
2	NBB2-8GM50-E2	11	
3	NEB3-8GM45-E2	6	
3	NEB3-8GM50-E2-V3	19	
4	NEB4-8GM45-E2	20	
4	NEB4-8GM50-E2-V3	19	

DC 4-Wire

A2 = pnp, antivalent
Normally Open and
Normally Closed

1.5	NBB1,5-8GM50-A2-V1	14	
1.5	NBB1,5-8GM60-A2	5	
1.5	NBB2-8GM30-A2-V1	13	

AC 2-/3-Wire

WS = Normally Open (2-Wire)

NAMUR/EN 60947-5-6
nominal voltage
8 V DC

0.8	NJ0,8-5GM-N	-	2)
-----	-------------	---	----

1.5	NCB1,5-6,5M25-N0	2	
1.5	NCB1,5-6,5M25-N0-V1	17	
1.5	NCB1,5-8GM25-N0	4	
1.5	NCB1,5-8GM25-N0-V1	10	

INDUCTIVE SENSORS CYLINDRICAL



... 6.5, ... 8GM

not embeddable

Sensing range	Part reference	Figure	Footnote
2	NBN2-8GM40-Z1	9	
2	NBN2-8GM50-Z1-V3	6	
2	NCN2-8GM40-Z1	-	
2	NCN2-8GM50-Z1-V3	6	
2	NJ2-6,5-40-E2	7	
2	NJ2-8GM40-E2	5	
2	NJ2-8GM40-E2-V1	2	
2	NBN2-8GM50-E2	-	
2	NBN2-8GM50-E2-V3	-	
3	NBN3-6,5M30-E2	3	
3	NBN3-6,5M25-E2-V3	-	
3	NBN3-8GM30-E2	9	
3	NBN3-8GM25-E2-V3	8	
3	NBN3-8GM30-E2-V1	10	
3	NBN3-8GM50-E2	-	
6	NEN6-8GM45-E2-V3	11	
6	NEN6-8GM45-E2-V1	12	
2	NBN2-8GM50-A2-V1	4	
2	NBN2-8GM60-A2	-	



... 12GM

embeddable

Sensing range	Part reference	Figure	Footnote
2	NBB2-12GM40-Z0	-	
2	NBB2-12GM40-Z0-V1	12	
2	NCB2-12GM40-Z1	-	
2	NCB2-12GM40-Z1-V1	12	
4	NCB4-12GM35-Z4	-	
4	NCB4-12GM40-Z4-V1	12	
2	NJ2-12GM40-E2	11	
2	NJ2-12GM40-E2-V1	4	
2	NBB2-12GM30-E2	16	
2	NBB2-12GM30-E2-V1	13	
2	NBB2-12GM50-E2	9	
2	NBB2-12GM50-E2-V1	5	
4	NBB4-12GM30-E2	16	
4	NBB4-12GM30-E2-V1	13	
4	NBB4-12GM30-E2-V3	14	
4	NBB4-12GM50-E2	6	
4	NBB4-12GM50-E2-V1	5	
6	NEB6-12GM50-E2	10	
6	NEB6-12GM50-E2-V1	4	
8	NEB8-12GM50-E2-V1	-	
2	NBB2-12GM60-A2	2	
2	NBB2-12GM60-A2-V1	8	
4	NBB4-12GM50-A2	10	
4	NBB4-12GM50-A2-V1	5	
2	NJ 2-12GM50-WS	10	
2	NJ 2-12GM50-WS-V11	4	
2	NJ 2-12GM50-WS-V12	4	
2	NJ 2-12GM50-WS-V13	4	
2	NCB2-12GM35-N0	1	
2	NCB2-12GM35-N0-V1	-	
4	NCB4-12GM40-N0	-	
4	NCB4-12GM40-N0-V1	-	

Other electrical versions on demand



Mounting clamps

Part reference	Figure
BF 4	1
BF 5	2
BF 6,5	3
BF 8	4
BF12	5
BF 18	6
BF 30	7
BF 40	8
BF12-F	9
BF18-F	10
BF30-F	11

Adjustable Brackets for Cylindrical Sensors:

The bracket (BF) for mounting cylindrical sensors directly on plane surfaces, can be adjusted with two screws.

Types BF...-F with fixed stop. In the event of a fault the sensor can be replaced without adjustment.



Mounting brackets

Part reference	Figure
MH 04-2681	1
MH 04-2057	2
MH 04-3742	3
MH 02-L	4
OMH-04	5

MH 04-2681

Mounting bracket for use with VariKont (... + U1 + ...) series. It is used to provide 360° turning range of the sensor and can be mounted on a C section rail acc. to EN 50024, allowing easy adjustment of the switching point within a range of max. 20 mm.

MH 04-2057

Mounting bracket for use with VariKont (... + U1+ ...) series, allowing easy adjustment of the switching point along the x-axis within a range of max. 30 mm.

MH 04-3742

Mounting bracket for use with VariKont M (... - M1K - ...) series, allowing easy adjustment of the switching point along the x-axis within a range of max. 12 mm.

MH 02-L

Mounting bracket for use with VariKont L (... - L2 - ...) series. It can be mounted on a C section rail acc. to EN 50024, allowing easy adjustment of the switching point within a range of max. 60 mm.

OMH-04

Mounting bracket for fastening M18 sensors to a 12 mm round steel. Adjustment via lock nuts and 360° turning range in two planes.



Cable protectors

Part reference	Figure
SM 8	1
SM 12	2
SM 14	3
SM 18	4
SM 30	5

SM...

These cable protectors are available for M8, M12, M14, M18 and M30 cylindrical sensors.

Cable connectors

Typecode Mating connectors

Typecode Sensors



All mating connectors are also available with 10 m and 20 m cable lengths. Irradiated or shielded cable on demand.

Part reference	
V1-G	1
V1-W	2
V1-G-2M-PVC (...-PUR)	3
V1-G-5M-PVC (...-PUR)	3
V1-G-E2-2M-PUR	11
V1-G-E2-5M-PUR	11
V1-G-N-5M-PUR	-
V1-W-2M-PVC (...-PUR)	4
V1-W-5M-PVC (...-PUR)	4
V1-W-E2-2M-PUR	5
V1-W-E2-5M-PUR	5
as plug: V1S-...	-
as ext. lead: ...-V1-G (-V1-W)	-
<hr/>	
V3-GM	6
V3-WM	7
V3-GM-2M-PUR	8
V3-GM-5M-PUR	8
V3-WM-E2-2M-PUR	9
V3-WM-E2-5M-PUR	9
as plug: V3S-...	-
as ext. lead: ...-V3-G (-V3-W)	-

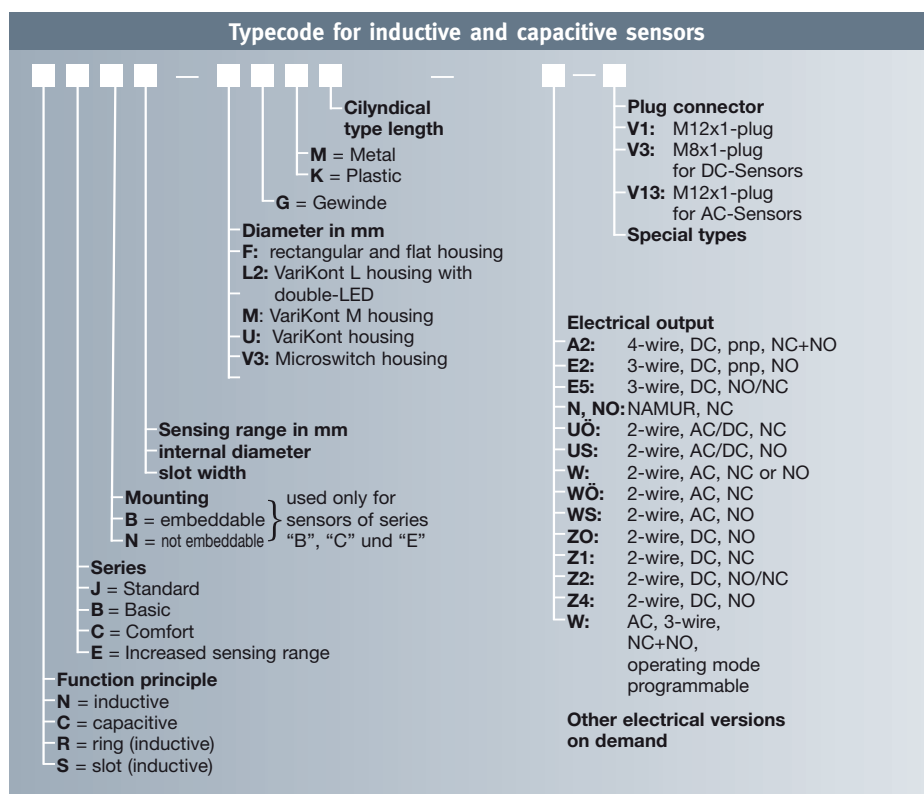
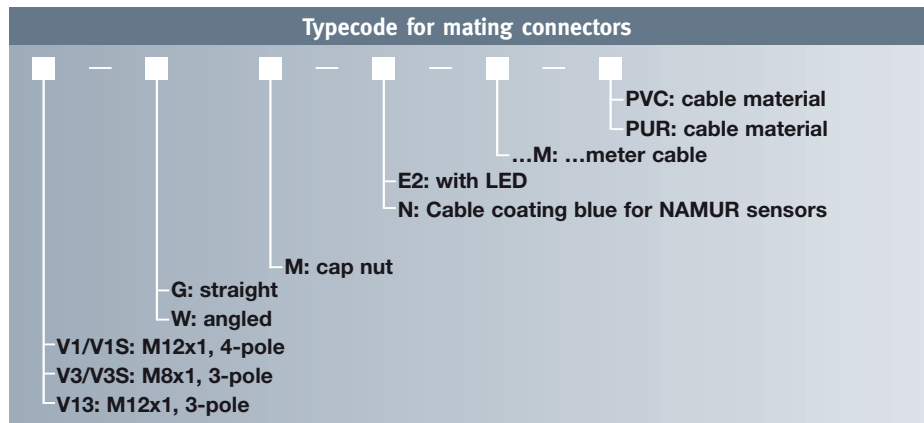

Inductive sensors rectangular and flat housing

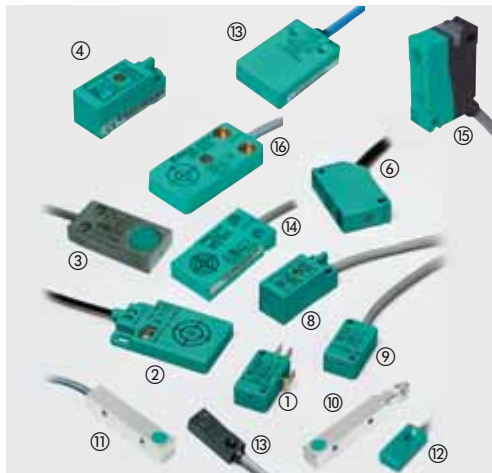

... F, ... F1, ... F9, ... F17, ... F33, F41, ... F79, ... V3

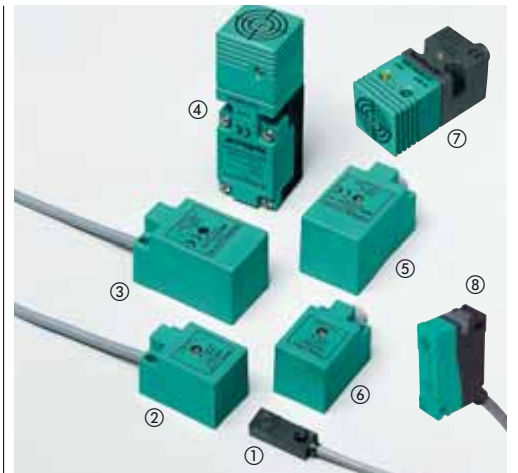

... F1, ... F10, ... F11, ... F29, VariKont M

Series:

Mounting:

embeddable

not embeddable

Electrical version

DC 2-Draht

Z = Normally Open
Z2 = Normally Closed or Normally Open
Z4 = Normally Open
10 V DC ... 30 V DC

Sensing range	Part reference	Figure	Footnote
3	NBB3-V3-Z4	9	

Sensing range	Part reference	Figure	Footnote
15	NCN15-M1K-Z2	4	
15	NCN15-M1K-E5	4	

DC 3-Wire

E2 = pnp Normally Open
E5 = Normally Open or Normally Closed
10 V DC ... 60 V DC
NJ .../NCB .../NCN ...

10 V DC ... 30 V DC
NBB .../NBN ...

Sensing range	Part reference	Figure	Footnote
6	NJ6-F-E2	13	
2	NBB2-F1-E2	15	
2	NBB2-F1-E2-V3	-	
4	NBB4-F1-E2	15	
4	NBB4-F1-E2-V3	-	
10	NCB10-F17-E2	2	
1.5	NBB1,5-F41-E2	11	
1.5	NBB1,5-F41-E2-V3	10	
1.5	NBB1,5-F41A-E2	-	1)
1.5	NBB1,5-F41A-E2-V3	-	1)
2	NBB2-V3-E2	9	
2	NBB2-V3-E2-V3	-	
2	NBB2-V3-E2-V5	1	
5	NBB5-F9-E2	8	
5	NBB5-F9-E2-V3	4	
5	NBB5-F33-E2	14	
8	NBB8-F33-E2	16	
5	NBB5-F33M-E2	3	
1.5	NBB1,5-F79-E2	12	

Sensing range	Part reference	Figure	Footnote
8	NBN8-F1-E2	8	
8	NBN8-F1-E2-V3	-	
4	NBN4-F29-E2	1	
10	NBN10-F10-E2	2	
10	NBN10-F10-E2-V1	6	
15	NBN15-F11-E2	3	
15	NBN15-F11-E2-V1	5	
15	NJ15-M1-E2-V1	7	3)

DC 4-Wire

A2 = pnp, antivalent
Normally Open and
Normally Closed

Sensing range	Part reference	Figure	Footnote
6	NJ6-F-A2	13	
2	NBB2-F29-A2	-	
4	NBB4-F1-A2	15	
5	NBB5-F33-A2	14	
5	NBB5-F33M-A2	3	

Sensing range	Part reference	Figure	Footnote
15	NJ15-M1K-A2	4	
4	NBN4-F29-A2	1	
8	NBN8-F1-A2	8	

AC 2-/3-Wire

U = Allstrom AC/DC
W = wiring prog. (2-wire)
20 - 250 V AC
W4 = antivalent (4-wire)
20 - 250 V AC

Sensing range	Part reference	Figure	Footnote
4	NBB4-F1-U0	15	
4	NBB4-F1-US	15	

NAMUR/EN 60947-5-6
nominal voltage
8 V DC

Sensing range	Part reference	Figure	Footnote
2	NJ2-F1-N	6	2)
2	NJ2-V3-N	9	2)
2	NJ2-V3-N-V5	-	2)
6	NJ6-F-N	13	2)

Sensing range	Part reference	Figure	Footnote
15	NCN15-M1K-N0	4	

INDUCTIVE SENSORS RECTANGULAR AND FLAT HOUSING



... VariKont, VariKont L

embeddable

Sensing range	Part reference	Figure	Footnote
15	NCB15+U1+Z2	2	
20	NBB20-L2-Z4-V1	1	
20	NBB20-U1-E2	3	
20	NBB20-L2-E2-V1	1	
20	NBB20-U1-A2	3	
20	NBB20-L2-A2-V1	1	
15	NJ15+U1+W	2	
15	NCB15+U1+N0	2	
20	NCB20-L2-N0-V1	1	

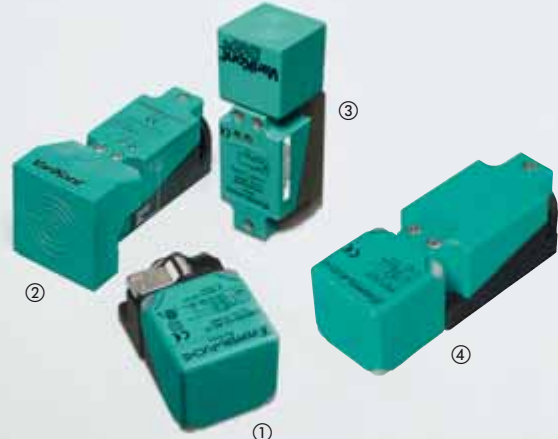

... VariKont, VariKont L

not embeddable

Sensing range	Part reference	Figure	Footnote
20	NCN20+U1+Z2	3	
30	NCN30+U1+Z2	3	
40	NCN40+U1+Z2	2	
40	NBN40-L2-Z4-V1	1	
40	NBN40-U1-E2	4	
40	NJ40+U1+E2	2	
40	NBN40-L2-E2-V1	1	
40	NBN40-U1-A2	4	
30	NBN30-L2-A2-V1	1	
40	NBN40-L2-A2-V1	1	
20	NCN20+U1+U	3	
30	NCN30+U1+U	3	
40	NCN40+U1+U	2	
20	NJ20+U1+W	3	
30	NJ30+U1+W	3	
40	NJ40+U1+W	2	
20	NCN20+U1+N0	3	
30	NCN30+U1+N0	3	
40	NCN40+U1+N0	2	
40	NCN40-L2-N0-V1	1	

INDUCTIVE SENSORS RECTANGULAR AND FLAT HOUSING



... FP, ... F23

Sensing range	Part reference	Figure	Footnote
50	NCN50-FP-Z2-P1	2	1)
50	NCN50-FP-Z4-V1	2	1)
50	NCB50-FP-Z2-P1	1	2)
50	NCB50-FP-Z4-V1	1	2)
100	NCN100-F23-E2-V1	3	1)
40	NCB40-FP-A2-P1	2	2)
40	NCB40-FP-A2-P1-V1	-	2)
50	NCN50-FP-A2-P1	2	1)
50	NCN50-FP-A2-P1-V1	-	1)
50	NCB50-FP-A2-P1	1	2)
50	NCB50-FP-A2-P1-V1	-	2)
40	NCB40-FP-W-P1	2	2)
50	NCN50-FP-W-P1	2	1)
40	NCB40-FP-N0-P1	-	2)
50	NCN50-FP-N0-P1	-	1)

Electrical output

2, 3, 4-Draht

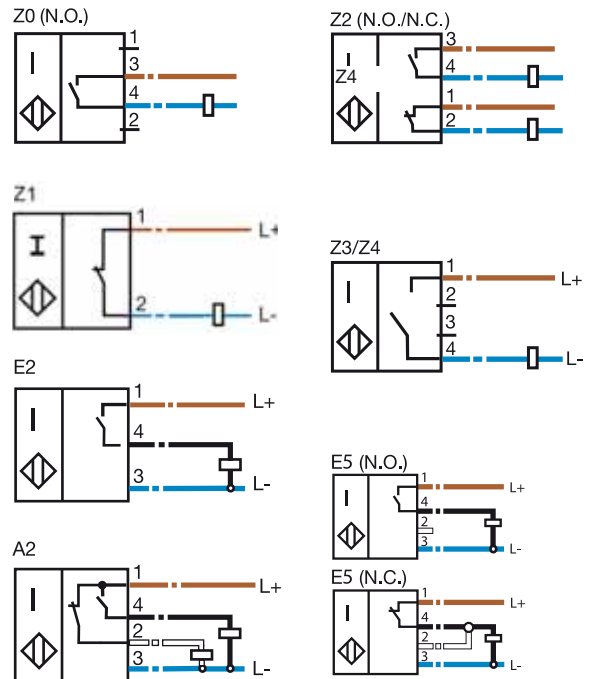

AC/DC, AC

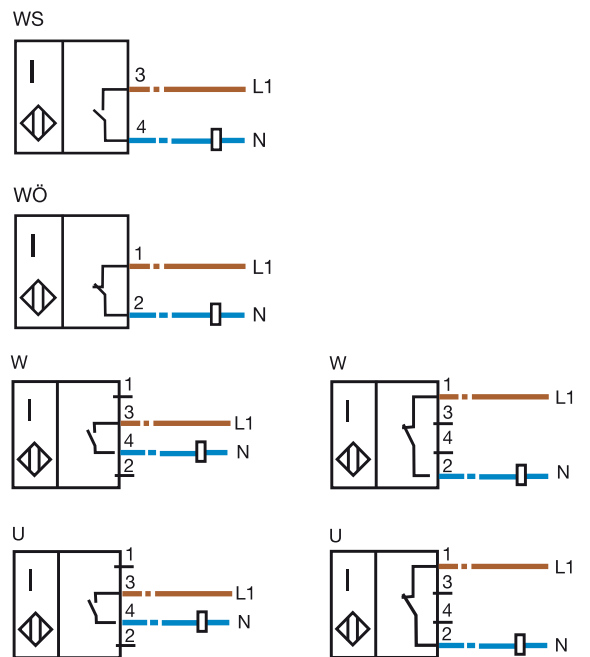

NAMUR

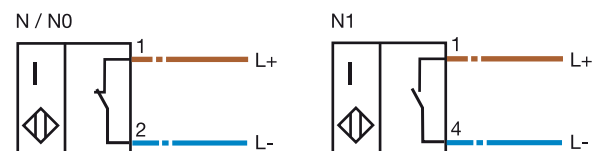

Footnoten: 1) not embeddable 2) embeddable

Inductive sensors slot and ring type

Series:

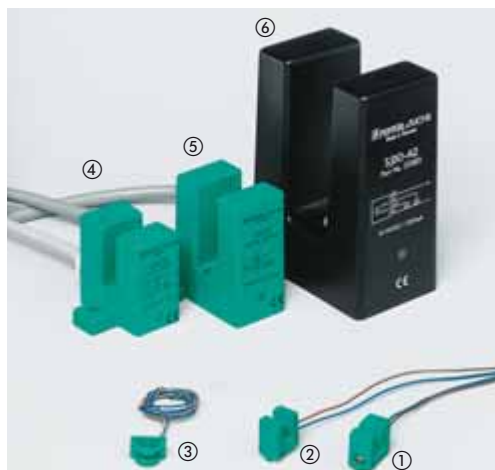

SB/SJ/SC 2 ... 30

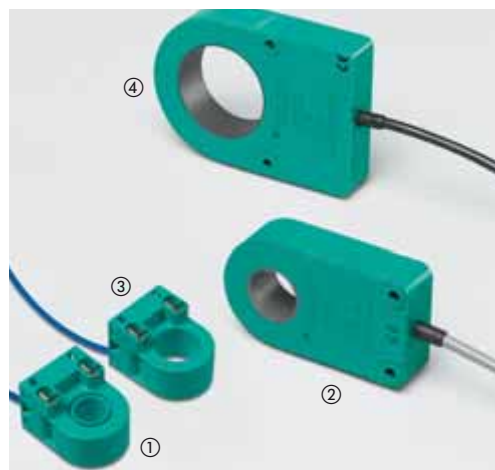

RJ/RC 10 ... 43

Electrical version

DC 2-Wire
Zo = Normally Open

Entry depth	Part reference	Figure	Footnote
5 ... 7	SB2-Z0	3	

DC 3-Wire
E2 = pnp Normally Open
10 V DC ... 60 V DC
SJ .../RJ ...

5 ... 7	SB3,5-E2	1	
13 ... 16	SJ10-E2	4	
17 ... 19	SJ15-E2	5	

DC 4-Wire
A2 = pnp, antivalent
Normally Open and
Normally Closed

17 ... 20	SJ15-A2	5	
27 ... 31	SJ30-A2	6	

AC 2-/3-Wire
WS = Normally Open (2-Wire)

18 ... 20	SJ15-WS	5	
27 ... 31	SJ30-WS	6	

NAMUR/EN 60947-5-6
nominal voltage
8 V DC

5 ... 7	SC2-N0	3	
5 ... 7	SC3,5-N0	1	
4 ... 6	SJ5-N	2	1)
13 ... 16	SJ10-N	4	1)
16 ... 19	SJ15-N	5	1)
27 ... 30	SJ30-N	6	1)

Inner diameter	Part reference	Figure	Footnote
21	RJ21-E2	2	
43	RJ43-E2	4	

10	RC10-14-N0	1	1)
15	RC15-14-N0	3	1)
21	RJ21-N	2	1)
43	RJ43-N	4	1)

INDUCTIVE POSITIONING SYSTEMS



Series:

... F90, ... F110, ... F112, ... F130

Mounting:

Electrical version	Sensing range	Part reference	Figure	Footnote
0 V ... 10 V 4 mA ... 20 mA	80	PMI80-F90-IU-V1	4	
	80	PMI80-F90-IE8-V15	4	
	104	PMI104-F90-IU-V1	4	
	104	PMI104-F90-IE8-V15	4	
	120	PMI120-F90-IU-V1	4	
	120	PMI120-F90-IE8-V15	4	
0 V ... 10 V	210	PMI210-F110-IU-V1	2	
	360	PMI360-F110-IU-V1	2	
0 V ... 10 V	14	PMI-14VF112-U-V3	1	
4 mA ... 20 mA	360°	PMI-360D-F130-IE8-V15	3	



REDUCTION FACTOR 1 SENSORS

Reduction factor 1 Sensors

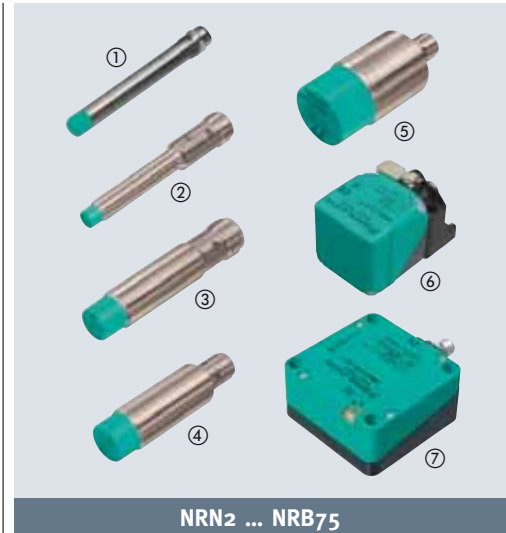

Series:

NRB2 ... NRB50

NRN2 ... NRN75

Mounting:

embeddable

not embeddable

Electrical version

DC 3-Wire
E2 = pnp Normally Open
10 V DC ... 30 V DC

Sensing range	Part reference	Figure	Footnote
2	NRB2-6,5M50-E2-V3	1	
2	NRB2-8GM40-E2-V1	2	
4	NRB4-12GM40-E2-V1	3	
8	NRB8-18GM50-E2-V	4	
12	NRB12-18GS40-E2-V1	4	
15	NRB15-30GM50-E2-V1	5	

Sensing range	Part reference	Figure	Footnote
6	NRN6-6,5M50-E2-V3	1	
6	NRN6-8GM40-E2-V1	2	
10	NRN10-12GM40-E2-V	3	
15	NRN15-18GM50-E2-V1	4	
30	NRN30-30GM50-E2-V1	5	

DC 4-Wire
A2 = pnp antivalent
Normally Open and
Normally Closed
10 V DC ... 30 V DC

Sensing range	Part reference	Figure	Footnote
20	NRB20-L3-A2-V1	6	
50	NRB50-FP-A2-P3-V1	7	

Sensing range	Part reference	Figure	Footnote
35	NRN35-L3-A2-V1	6	
40	NRN40-L3K-A2-V1	6	
75	NRN75-FP-A2-P3-V1	7	



INDUCTIVE SENSORS CYLINDRICAL



... 12GM

not embeddable

Sensing range	Part reference	Figure	Footnote
4	NBN4-12GM40-Z0	-	
4	NBN4-12GM40-Z0-V1	12	
4	NCN4-12GM40-Z1	-	
4	NCN4-12GM40-Z1-V1	12	
8	NCN8-12GM35-Z4	-	
8	NCN8-12GM40-Z4-V1	12	
4	NJ4-12GM40-E2	3	
4	NJ4-12GM40-E2-V1	11	
4	NBN4-12GM50-E2	-	
4	NBN4-12GM50-E2-V1	11	
7	NBN7-12GM35-E2	4	
7	NBN7-12GM35-E2-V1	8	
8	NBN8-12GM50-E2	2	
8	NBN8-12GM50-E2-V1	6	
10	NEN10-12GM50-E2-V1	7	
4	NBN4-12GM35-A2-V1	-	
4	NBN4-12GM60-A2	5	
4	NBN4-12GM60-A2-V1	10	
8	NBN8-12GM50-A2	2	
8	NBN8-12GM50-A2-V1	6	
4	NJ4-12GM50-WS	-	
4	NJ4-12GM50-WS-V11	7	
4	NJ4-12GM50-WS-V12	7	
4	NJ4-12GM50-WS-V13	7	
4	NCN4-12GM35-N0	1	
4	NCN4-12GM35-N0-V1	12	



... 18GM

embeddable

Sensing range	Part reference	Figure	Footnote
5	NBB5-18GM40-Z0	2	
5	NBB5-18GM40-Z0-V1	7	
5	NCB5-18GM40-Z1	2	
5	NCB5-18GM40-Z1-V1	7	
8	NCB8-18GM50-Z4	-	
8	NCB8-18GM50-Z4-V1	-	
5	NJ5-18GM50-E2	10	
5	NJ5-18GM50-E2-V1	14	
5	NBB5-18GM20-E2	9	
5	NBB5-18GM20-E2-V1	11	
5	NBB5-18GM50-E2	3	
5	NBB5-18GM50-E2-V1	8	
8	NBB8-18GM30-E2	12	
8	NBB8-18GM30-E2-V1	13	
8	NBB8-18GM50-E2	3	
8	NBB8-18GM50-E2-V1	8	
12	NEB12-18GM50-E2	10	
12	NEB12-18GM50-E2-V1	5	
5	NJ5-18GM50-A2	10	
5	NJ5-18GM50-A2-V1	14	
5	NBB5-18GM60-A2	3	
5	NBB5-18GM60-A2-V1	6	
8	NBB8-18GM60-A2	3	
8	NBB8-18GM60-A2-V1	6	
5	NBB5-18GM60-WS	3	
5	NBB5-18GM60-WS-V11	-	
5	NBB5-18GM60-WS-V12	-	
5	NCB5-18GM40-N0	1	
5	NCB5-18GM40-N0-V1	4	
8	NCB8-18GM40-N0	1	
8	NCB8-18GM40-N0-V1	4	

Other electrical versions on demand

INDUCTIVE SENSORS CYLINDRICAL



... 18GM

not embeddable

Sensing range	Part reference	Figure	Footnote
8	NBN8-18GM40-Z0	1	
8	NBN8-18GM40-Z0-V1	-	
8	NCN8-18GM40-Z1	1	
8	NCN8-18GM40-Z1-V1	-	
12	NCN12-18GM50-Z4	-	
12	NCN12-18GM50-Z4-V1	7	
8	NJ8-18GM50-E2	2	
8	NJ8-18GM50-E2-V1	5	
8	NBN8-18GM50-E2	3	
8	NBN8-18GM50-E2-V1	5	
12	NBN12-18GM35-E2	-	
12	NBN12-18GM35-E2-V1	9	
12	NBN12-18GM50-E2	3	
12	NBN12-18GM50-E2-V1	5	
20	NEN20-18GM50-E2-V1	5	
8	NJ8-18GM50-A2	2	
8	NJ8-18GM50-A2-V1	8	
8	NBN8-18GM60-A2	-	
8	NBN8-18GM60-A2-V1	8	
12	NBN12-18GM50-A2	3	
12	NBN12-18GM50-A2-V1	5	
8	NBN8-18GM60-WS	-	
8	NBN8-18GM60-WS-V11	-	
8	NBN8-18GM60-WS-V12	-	
8	NCN8-18GM40-N0	4	
8	NCN8-18GM40-N0-V1	6	



... 30GM

embeddable

Sensing range	Part reference	Figure	Footnote
10	NBB10-30GM40-Z0	11	
10	NBB10-30GM40-Z0-V1	7	
10	NCB10-30GM40-Z1	-	
10	NCB10-30GM40-Z1-V1	-	
15	NCB15-30GM50-Z4	-	
15	NCB15-30GM50-Z4-V1	-	
10	NJ10-30GM50-E2	8	
10	NJ10-30GM50-E2-V1	-	
10	NBB10-30GM50-E2	10	
10	NBB10-30GM50-E2-V1	3	
15	NBB15-30GM30-E2	5	
15	NBB15-30GM30-E2-V1	2	
15	NBB15-30GM50-E2	10	
15	NBB15-30GM50-E2-V1	3	
22	NEB22-30GM60-E2-V1	6	
10	NJ10-30GM50-A2	8	
10	NJ10-30GM50-A2-V1	4	
10	NBB10-30GM60-A2	9	
10	NBB10-30GM60-A2-V1	4	
15	NBB15-30GM60-A2	-	
15	NBB15-30GM60-A2-V1	6	
10	NBB10-30GM50-WS	10	
10	NBB10-30GM50-WS-V11	-	
10	NBB10-30GM50-WS-V12	-	
15	NBB15-30GM50-WS	10	
15	NBB15-30GM50-WS-V11	-	
15	NBB15-30GM50-WS-V12	-	
10	NCB10-30GK40-N0	-	
10	NCB10-30GM40-N0	1	
10	NCB10-30GM40-N0-V1	7	



... 30GM

not embeddable

Sensing range	Part reference	Figure	Footnote
15	NBN15-30GM40-Z0	6	
15	NBN15-30GM40-Z0-V1	1	
15	NCN15-30GM40-Z1	8	
15	NCN15-30GM40-Z1-V1	9	
25	NCN25-30GM50-Z4	2	
25	NCN25-30GM50-Z4-V1	-	
15	NJ15-30GM50-E2	3	
15	NJ15-30GM50-E2-V1	-	
15	NBN15-30GM50-E2	4	
15	NBN15-30GM50-E2-V1	5	
22	NBN22-30GM35-E2	-	
22	NBN22-30GM35-E2-V1	-	
25	NBN25-30GM50-E2	4	
25	NBN25-30GM50-E2-V1	5	
40	NEN40-30GM60-E2-V1	-	
15	NJ15-30GM50-A2	3	
15	NJ15-30GM50-A2-V1	7	
15	NBN15-30GM60-A2	2	
15	NBN15-30GM60-A2-V1	-	
15	NCN15-30GK40-N0	-	
15	NCN15-30GM40-N0	6	
15	NCN15-30GM40-N0-V1	1	

Sensor tester



ST03

Sensor tester (basic version)

The basic sensor tester for 2- and 3-wire sensors as NAMUR or DC version. Switching function with optical and audible indication.



1-1350

Sensor tester (advanced version)

The advanced sensor tester for 2-, 3- and 4-wire sensors in NAMUR, DC or AC version. The switching function is indicated with LEDs.

IN OUR CATALOG SENSORS FOR FACTORY AUTOMATION YOU WILL FIND:

- Position indicators
- Analog sensors
- Sensors with direct connection to the AS-Interface
- Special sensors with the following features:
 - high pressure resistant up to 350 bar
 - temperature resistant up to 250 °C
 - reduction factor 1
 - sensors for safety related applications
 - weld field immune
 - increased consistency up to IP69k



FACTORY AUTOMATION – SENSING YOUR NEEDS



Pepperl+Fuchs sets the standard in quality and innovative technology for the world of automation. Our expertise, dedication, and heritage of innovation have driven us to develop the largest and most versatile line of industrial sensor technologies and interface components in the world. With our global presence, reliable service, and flexible production facilities, Pepperl+Fuchs delivers complete solutions for your automation requirements – wherever you need us.

Contact

Pepperl+Fuchs GmbH
Lilienthalstraße 200
68307 Mannheim · Germany
Tel. +49 621 776-4411 · Fax +49 621 776-27-4411
E-mail: fa-info@pepperl-fuchs.com

Worldwide Headquarters

Pepperl+Fuchs GmbH · Mannheim · Germany
E-mail: fa-info@pepperl-fuchs.com

USA Headquarters

Pepperl+Fuchs Inc. · Twinsburg, OH · USA
E-mail: fa-info@us.pepperl-fuchs.com

Asia Pacific Headquarters

Pepperl+Fuchs Pte Ltd · Singapore
Company Registration No. 199003130E
E-mail: fa-info@sg.pepperl-fuchs.com

www.pepperl-fuchs.com

 **PEPPERL+FUCHS**
SENSING YOUR NEEDS